



-INDIANOIL'S WINNING FORMULA

PRESENTS

# FMSCI Indian National Drag Racing Championship 2024 (4 WHEELERS)

## CHAMPIONSHIP REGULATIONS

Organised By:



SPEEDWAY MOTORSPORTS, Hyderabad

&

Vroom Motorsports, Bangalore.



APPROVED BY

**fmsci**

The Federation of Motor Sports Clubs of India

(National Sports Federation recognized by the FIA, FIA)  
Official Mobile Application, <https://onelink.to/3scppa> (IOS / ANDROID) or  
[www.vroomgeneva.com](http://www.vroomgeneva.com) , by the appropriate closing dates.



QR code of Official Mobile Application for download

## TABLE OF CONTENTS

1. INTRODUCTION	03
2. ORGANIZATION	03
3. PROGRAMME & SAFETY PLAN	05
4. ENTRIES & CLASSIFICATION	06
5. INSURANCE	06
6. ADMINISTRATIVE CHECKS / GENERAL UNDERTAKING / INDEMNITY	08
7. DRIVER'S BRIEFING & PRE-EVENT SCRUTINEERING, SEALING AND MARKING	09
8. ADVERTISEMENT AND IDENTIFICATION	10
11. POINTS	11
12. RUNNING OF THE EVENT	11
13. PENALTIES & RESULTS	12
14. PROTEST & APPEAL	13
15. PRIZES & TROPHY	14
16. IDENTIFICATION OF OFFICIALS	14
16. NAMES AND PHOTOGRAPHS OF CRO'S	15
17. SUSTAINABILITY	17
16. APPENDIX 1	18

## **INTRODUCTION**

The **INDIAN OIL STORM X PRESENTS FMSCI INDIAN NATIONAL DRAG RACING CHAMPIOSHIP ( 4-WHEELERS )** is run in compliance with the **2024** International Sporting Code of the Federation Internationale de l' Automobile (FIA), **2024** FMSCI General Prescriptions for Drag Racing, the relevant Drag Technical Regulations and these Supplementary Regulations (SRs).

The Federation of Motor Sports Clubs of India (FMSCI) is the National Sporting Authority (ASN) of FIA in India.

Modifications, amendments and / or changes to these SRs will be announced only by numbered and dated bulletins, issued by the organizers, approved by the FMSCI or Stewards.

## **ACQUAINTANCE WITH AND SUBMISSION TO RULES:**

1. Every person or group of persons, organizing a competition or taking part therein shall be deemed to be acquainted with all the relevant rules and regulations of the FMSCI
2. All competitors must sign the indemnity and declaration form, which are enclosed with the Entry Form
3. These are conditions precedent attached to the submission of entries and taking part in an event and all competitors participating shall be bound by them and also the rules and regulations hereinafter set out or amendments made thereto.
4. Shall undertake to submit themselves without reserve to the above and to the decision and consequences resulting therefrom.

## **1. ORGANISATION**

This event will run in accordance with the International Sporting Code of the FIA, the 2024 FMSCI GP & 4W Technical Regulations for Drag Racing and NCR of FMSCI applicable - the ASN of the FIA in India, (and its appendices) and these Supplementary Regulations.

### **1.1 Definitions**

Name of the event: **INDIAN OIL STORM X PRESENTS FMSCI INDIAN NATIONAL 4W DRAG RACING CHAMPIOSHIP 2024**

Organisers: **SPEEDWAY MOTORSPORTS, Hyderabad**

Associate Organiser **VROOM**

**Sponsors: INDIAN OIL STORM X**

FIA: Federation Internationale de l'Automobile

FMSCI: The Federation of Motor Sports Clubs of India

NCR: National Competition Rules

ASN: National Sporting Authority

## 1.2 Organising Committee:

S MANDEEP SINGH DHINGRA	TARIQ MOHSIN	NARESH C RAMAN
-------------------------	--------------	----------------

## 1.4 Headquarters / Official Notice Board:

Till Wednesday

Hyderabad - **SPEEDWAY MOTORSPORTS**, Legend Chawla Apartments, 401/A Road no 5 Banjara Hills, Hyderabad - 50034. **Mobile: 9573471999; 9246526520.**

Bangalore -: **VROOM** #638/669 ; 4<sup>TH</sup> FLOOR 1<sup>ST</sup> STAGE 2<sup>ND</sup> BLOCK HBR LAYOUT BENGALURU - 560043. **Mobile: 7022450500**

Friday to Sunday - TAAL, Hosur

## 1.5 Championship Officials for Round 3 & 4

Chief Steward	:	TBA
2 <sup>nd</sup> Steward	:	TBA
Club Steward	:	Dr. I Venkat Rao
Clerk of the Course	:	Mr. S. Mandeep Singh Dhingra
Secretary of the Meet	:	Mr. Naresh C Raman
Deputy Sec. of the Meet	:	Mr. T Nagarajan
Chief Time Keeper	:	Mr. Samir Suneja
Competitor Relation Officer	:	Mr Tariq Mohsin
Chief Safety Officer	:	Mr. Abdul Mateen
Chief Scrutineer 4w	:	Mr. Subhash Chandra Bose
Asst. Scrutineers 4w	:	Mr. Mark Sanjay / TBA
Technical Delegate	:	Mr. K.R. Kumar
Media Relations Officer	:	Mr Mohammed Anas Javeed
Results Co-ordinator	:	Mr Kamesh Chander
Sustainability Officer	:	Mr Naresh C Raman
Paddock in Charge	:	Mr Saad Khan MJ /
Asst. Paddock in Charge	:	Mr. Shabbir Ali / Mr : Mujahid
Parc Ferme in Charge	:	Mr Mohammed Jameel
Asst Parc Ferme in Charge	:	Mr Rizwan
Left / Right Lane Marshal	:	TBA
Flying Finish / Holding Area	:	Mr Abdul Mateen / Mr Asam

## 1.6 Rights & Obligations Of The Organisers

The Organisers and Stewards of the meet may issue any bulletins to participants at any time as per the Code with the approval of FMSCI / Stewards. These bulletins shall be posted on the official notice board. Written bulletins when issued shall have the same legal force as these supplementary regulations. All bulletins will be communicated, dated and sequentially numbered and written acknowledgement will be taken from all competitors.

The stewards of the meet are empowered to take a decision on any case not covered by the present regulations. The Stewards of the Meet have the right to delete and / or shorten the track should they deem it necessary or expedient at any time or due to safety or FORCE MAJEURE.

## 1.7 DATES & VENUES

Round	Date	Venue
1	17 <sup>th</sup> May 2024	Taneja Aerospace ( TAAL ) , Hosur
2	19 <sup>th</sup> May 2024	Taneja Aerospace ( TAAL ) , Hosur
3	21 <sup>st</sup> Dec 2024	Taneja Aerospace ( TAAL ) , Hosur
4	22 <sup>nd</sup> Dec 2024	Taneja Aerospace ( TAAL ) , Hosur

## 1.8 PROGRAMME

	Description	Venue	Time and Date
A	Entries open with publication of these Regulations		Publication of SR's
B	Closing of entries		Normal - 5 days before the event Late - 3 days before the event
C	Document Verification	TAAL , Hosur	As per schedule released for the event
D	Pre-event scrutiny of vehicle	TAAL , Hosur	As per schedule released for the event
E	4W PRACTICE	TAAL , Hosur	As per schedule released for the event
F	4 wheeler's Compulsory Driver's Briefing	TAAL , Hosur	As per schedule released for the event
G	Prize Distribution	TBA	TBA

## 1.9 General Conditions

Event Status: National Championship

**TRACK** Round 1 & 2 (Taneja Aerospace, Hosur)

Surface : Tarmac

Length of Track : 2200 meters, 402 meter race distance

Braking Distance : 1000 + meters

**TRACK** Round 3 & 4 (Taneja Aerospace, Hosur)

Surface : Tarmac

Length of Track : 2200 meters, 402 meter race distance

Braking Distance : 1000 + meters

## **1.10 SAFETY PLAN**

- Fire - Fire extinguisher every 100 Mts. also at start, finish, parc ferme and parking areas.
- Accident - FIV placed at start. One tow truck at start.
- Medical - One trauma ambulance equipped with doctor and paramedic placed at start point. Multi-Specialty hospital, situated at about 11.2 Kms. from event site.

## **1.11 FIRE EXTINGUISHERS – MINIMUM REQUIREMENTS**

- 2 No's 25 Kg on a pick up truck
- 4 Nos of 6 Kg extinguishers at the start
- 1+1 (one each lane), 6 kgs extinguishers every 100 meters.
- Fire tender vehicle at Flying Finish

## **2 Entries ,Entry Fees & Insurance**

### **2.1 Eligible Competitors**

Any competitor who has the following documents is allowed to participate in this event.

- Valid driving license
- FMSCI Competition license - Minimum requirement is 4W Full Drag or 4W Road Racing license valid for 2024. Mandatory Insurance Policy for the championship please visit <https://www.fmsci.co.in/wp-content/uploads/2024/03/Circular-01.2024.insurance.pdf>

2.1.1 Under the laws of India, any accident out of which a claim may arise should be reported to the nearest police station.

2.1.2 Under no circumstances will any competitor, crew member, Marshal or official admit any liability or sign any form or paper which may admit or indicate liability of the sponsors, the organizers, the owners of the venue or the FMSCI in any accident or incident which may arise.

2.1.3 Any indemnity and / or declaration as prescribed if signed by a person under the age of 18 years shall be counter signed by that person's parent or guardian whose full name and address shall be given. Failure to do so will result in the competitor not being allowed to start.

2.2 The Entry Fee shall be as follows (Excluding 18% GST) - Per Round.

**2.2.1 (Minimum number of entries for each class is 8. If insufficient entries are received for a class, the class may be cancelled or merged with the next higher class)**

### **2.2.2**

<b>Category / Classes</b>	<b>Class Code</b>	<b>Individual (INR)</b>	<b>Team (INR)</b>
<b>Pro Stock – Petrol</b>			
1. 1151 to 1450 CC	<b>K2</b>	10000	12000
2. 1451 to 1650 CC	<b>K3</b>	10000	12000
3. 1651 to 2050 CC	<b>K4</b>	10000	12000
4. 2051 to 2550 CC	<b>K5</b>	10000	12000
5. 3061 to 4002 CC	<b>K7</b>	10000	12000
6. 4003 to 5100 CC	<b>K8</b>	10000	12000
<b>Pro Stock – Diesel</b>			

7. 1651 to 2050 CC	<b>L4</b>	10000	12000
8. 2551 to 3060 CC	<b>L6</b>	10000	12000
<b>Indian Open</b>			
9. Up to 2750 CC	<b>M1</b>	12000	14000
10. Up to 4002 CC	<b>M2</b>	12000	14000
11. Unlimited	<b>M3</b>	12000	14000
12. <b>Unrestricted</b>	<b>N1</b>	12000	14000

**2.2.3 Entry Forms and Fees (per round) 10% discount if paid for all the rounds together in the beginning of the year.**

**2.2.4 Team Entry shall refer to any vehicle which has a team name mentioned on the vehicle in the form of a sticker, paint work or any other form.**

**2.2.5 Late fee entries shall be 50% additional of the normal fee.**

**2.2.6 Participants must fill up the Official Entry Form online available on our Official Mobile Application, <https://onelink.to/3scppa> (IOS / ANDROID) or [www.vroomgeneva.com](http://www.vroomgeneva.com) , by the appropriate closing dates.**



**QR code of Official Mobile Application for download**

**2.2.7 Payments for the Rounds & if paid for full championship should be made in cash or by means of Demand Draft payable in favor of **Vroom** payable at Bangalore. You can also deposit the amount directly into our following account.**

Bank : **ICICI BANK**  
Branch : **COX TOWN**  
A/c Name : **VROOM**  
A/c Type : **Current**  
A/c Number : **025205004825**  
IFSC Code : **ICICI0000252**

**2.2.8 The maximum number of entries shall be for 50 per class. Entries shall be accepted on a "first come first served" basis.**

**2.2.9 Minimum number of entries for each class is 8. If insufficient entries are received for a class, the class may be cancelled or merged with the next higher class.**

**2.2.10 Entry forms, which are not complete, except as permitted by these regulations or which are not accompanied with the appropriate fee, may be rejected. All competitors and team / crew will have to submit a separate health declaration / indemnity form and adhere to all standard operating procedures to help tackle the covid 19 virus.**

**2.2.11 A separate entry form is to be completed for each round.**

**2.2.12 All completed entries must reach the organiser before the closing date and time, failing which they may be deemed null and void.**

2.2.13 By the very fact of signing the entry form, the entrant as well as the driver submit and bind themselves to resort to the International Sporting Code of the FIA, the NCR of the FMSCI applicable and these supplementary regulations.

2.2.14 An entry form that contains false and / or incorrect statements shall be deemed null and void, the entry fee may be forfeited and the entrant/driver disqualified from the meet.

2.2.15 Each participant shall be given 1 mechanics pass per CAR entered. Photographs for the pit crew should be presented at the time of documentation; failure to do so will result in pit crew being denied entry into the paddock.

2.2.16 Entry fees or part thereof will be refunded only in the following circumstances If any entry is not accepted – 100%

- If the date of the meet is altered - 100%
- If the meet is cancelled - 100%

**2.2.17 SPEEDWAY MOTORSPORTS & VROOM MOTORSPORTS PVT. LTD. HAS THE RIGHT TO ACCEPT OR REJECT ANY ENTRY AFTER PROVIDING SUFFICIENT REASON FOR THE SAME.**

### **3. ADMINISTRATIVE CHECKS & DOCUMENT VERIFICATION**

**3.1** The Entrant should produce original copies (photocopies are to be sent along with the entry form) of the following for inspection at the time of submitting the vehicle for scrutiny and administrative checks:

3.1.1 High Risk personal Accident Insurance top up policy as suggested by the federation is **COMPULSORY**

3.1.2 FMSCI Competition license or licence number confirmed by FMSCI -- **COMPULSORY**

3.1.3 Copy of licence to be handed over at the time of entry or license number confirmed by FMSCI - **COMPULSORY**

3.1.4 Copy of Registration book/ ownership document to be handed over at the time of entry – **COMPULSORY**

**3.1.5** Authority letter from the owner if the driver is not the owner of the Vehicle.- **COMPULSORY**

**3.1.6 In case of race built CARS, documents need to provide clarity of ownership)**

**3.2** All the above documents shall be valid for both the days of the event. Competitors are required to carry all the above documents throughout the event.

**3.3** The administrative checks of these documents have to be completed to be eligible to enter into paddock area.

### **4. GENERAL UNDERTAKING**

4.1 All DRIVERS and ENTRANTS participating in the event undertake, on behalf of themselves, their employees and agents, to observe all the provisions of the International Sporting Code (the Code), the NCR of the FMSCI applicable and these Supplementary Regulations.

4.2 Entrants, Driver, assistants and guests must at all times wear the appropriate identification credentials that have been handed to them by the Organisers. They shall also



wear face mask and follow the SOP as prescribed by the federation to deal with the Covid 19 pandemic.

## 5. NON-LIABILITY OF AND INDEMNITY TO THE ORGANISERS

5.1 The organisers decline liability for any accident caused by or to any entrant or driver or third party or to the competing vehicle either before or during the events. The organisers also decline liability for breach of any law in which the competitor may be involved in and each competitor shall decline to the duly authorised official or to the organisers, in regards to any and all incidents from which liability may arise and shall indemnify the organisers, sponsors, FIA, FMSCI / SPEEDWAY MOTORSPORTS, VROOM MOTORSPORTS PVT. LTD relevant State Government & Govt. of India in regards to all liabilities. The entrant and his executors/administrators and legal representatives shall not have any claim whatsoever on the organisers , sponsors, FIA, FMSCI, and relevant State Govt. & Govt. of India, their officials, agents, representatives, employees, owners of the grounds and all persons assisting them in the events either before or during the event.

**5.2 Each entrant and competitor will execute and deliver an indemnity on INR 100 Stamp Paper, declaration and undertaking as stated at the back of the entry form. Failure to do so will result in the competitor not being allowed to start.**

***5.3 Entrant and Driver's attention is particularly drawn to the fact that normal insurance policies issued in India do not provide cover for motor sports.***

5.4 Under the laws of India any accident out of which a claim may arise should be reported to the nearest police station. Under No circumstances will any Driver, Competitor, Marshal or official admit any liability or sign any form or paper which may admit or indicate liability of the organizers, sponsors, and the owners of the venue or the FMSCI in any accident or incident.

## 6. DRIVERS BRIEFING

6.1 The Drivers briefing for all the drivers will be held online / offline at time / venue noted in the official program / official Whatsapp Channel Groups / Official Mobile Application. All the drivers MUST attend the briefing meeting where an attendance will be recorded. Non-attendance will be reported to the Stewards of the meet and shall entail a penalty INR 2,000 /- AND/OR Disqualification.



**QR code of Official Mobile Application for download**

## 7. SCRUTINY

7.1 Any Car taking part in the event must be presented by the driver or his official representative to Scrutineering, at time and venue noted in the official programme of each round. Competitors reporting later than their schedule will be charged a late scrutiny fee of Rs.100/- per minute later than their slot up to maximum of 15 minutes lateness allowed after which the participant will be disqualified.

7.2 Each car must carry the competition number and the advertising stickers provided by the Organisers when it reports for Scrutiny. The details of where to put the advertising stickers

and the competition number will be given on date and time noted in the official programme of each round.

7.3 All Drivers must comply with the minimum following requirements as specified in the 2024 4W Drag Technical regulations.

7.4 The first three cars in each category may be subject to compulsory post event scrutiny. Other finishers will be held in parc ferme and can only leave on the approval of the organiser. The participants must come prepared with their own mechanics at the time of Scrutiny.

## **8. APPAREL**

### **8.1 APPAREL**

Each member of a participant crew must be fully attired when present in the staging, starting and competition areas of the race track. Shoes are mandatory. Shorts, bare legs, tank tops, or bare torsos are prohibited when riding in any class. See Class Requirements.

### **8.2 APPEARANCE**

Vehicles participating in drag racing events must be presentable in appearance at all times; those considered improperly prepared may be rejected by the scrutineer. The appearance of personnel attending contestant vehicles is equally important, and is subject to the same considerations

## **9. ADVERTISING**

9.1 The competitors are allowed to carry any other kind of advertisements on their car provided that:

9.1.1 It is authorized by the National laws and FMSCI regulations

9.1.2. It is not likely to cause any offense

9.1.3. It is not political or religious in nature

9.1.4. It does not encroach upon the space reserved for plates, competition number and organisers tickers

9.1.5. It does not interfere with driver vision.

9.1.6. Compulsory stickers as provided by the organisers must be affixed before scrutiny and must remain affixed throughout the event.

9.8.7. It is not of any competing brand that has sponsored the event.

**(REFER APPENDIX 1)**

## **10. ELIGIBLE CLASSES AND CATEGORIES AND TECHNICAL REGULATIONS**

10.1 Minimum number of entries for each class is 8. However, if insufficient entries have been received for a class, the organizers reserve the right to cancel or abandon a class or merge a class with a higher class in liaison with the Stewards of the event, if they feel appropriate.

10.2 Maximum of 2 Drivers is allowed for each car in any category. Any participant cannot take part in multiple cars in a single class.

**10.3 Fuel:** Free

10.4 ANY liquid leak will prevent car from being permitted to stage or race.

10.5 Brakes must be in good order and capable of providing proper control at the car potential top speed

10.6 Tyre MUST BE AS PER FMSCI DRAG TECHNICAL 4W REGULATIONS 2024. **Any tyres showing damage and/or signs of serious wear are prohibited.**

For more details visit: <https://www.fmsci.co.in/wp-content/uploads/2024/02/2024-4W-Technical-RegulationsDrag-Racing.pdf>

## 11. POINTS

11.1 Points for Driver Titles and Team will be awarded for each race according to the following scale and all race points will count for the National Championship Winner. Top 2 finishers points of the team (per race) will only count towards the team championship points. **To qualify for the overall championship, both drivers and teams must participate in every round of the championship.**

11.2 In case of a tie in championship points, the driver with the maximum number of 1<sup>st</sup> place will be declared the winner. If the tie still exists, the driver with the maximum number of 2<sup>nd</sup> place will be declared the winner. This will be calculated for each position till a clear winner is determined. If the tie cannot be broken based on position, then the fastest time (ET) set by the driver in both the rounds combined will be declared the winner.

### 11.3 POINTS TABLE

1 <sup>ST</sup> PLACE	25	5 <sup>TH</sup> PLACE	10
2 <sup>ND</sup> PLACE	18	6 <sup>TH</sup> PLACE	08
3 <sup>RD</sup> PLACE	15	7 <sup>TH</sup> PLACE	06
4 <sup>TH</sup> PLACE	12	8 <sup>TH</sup> PLACE	04

## 12. RUNNING OF EVENT

**12.1 BURNOUTS ARE ONLY PERMITTED IN THE PRE STAGING AREA ON THE DRAG STRIP.**

**12.2 MANDATORY OFFICIAL PRACTICE:** It's mandatory for all competitors to take at least one practice run. In case of multiple entries by a driver, a maximum of two practice runs will be permitted. All cars must self-start and self-stage. A DRIVER cannot drive more than one car in the same Class. Same vehicle can be used for multiple categories if it falls under that particular cubic capacity bracket. Vehicles must remain in the same category entered, with a maximum of TWO registered drivers.

### **12.3 Starting Line & Staging Procedures**

The class that is to run will be announced, followed by the competition numbers of each car participating in that class. **Competitors will be paired using draw of lots per class to form the start order.** Start Order / Competition numbers will be announced in pairs in the order of racing precedence. The first pair of car will be called to the starting line by their competition numbers. When the first car arrives at the starting line, the second car has one (1) minute to arrive and stage at the starting line. Car that fails to stage at the starting line within one minute may be immediately disqualified.

- 12.4 There will be no choice of lane. Any competitor found not listening to the start line marshal or any other official at the start, may be disqualified immediately.
- 12.5 The Starting Lights will be 3 Amber lights followed by a Green light for GO.
- 12.6 The Cars will be judged according to timings. Timing will be recorded by a beam trigger. The timing will be recorded from the time the car starts (beam is open) up to when the driver crosses the finish line.
- 12.7 If a driver makes a false / jump start or jumping the lanes, the RED light will come on and the participant may be DISQUALIFIED from that particular run.
- 12.8 Once the vehicle has finished its run, the competitors have to go to Holding Area and wait. The vehicle will only return behind the „OFFICIAL SAFETY CAR“ under the instruction of the holding area in-charge speed limit will be 60 Kms. / hr. OR, in the absence of safety car, the competitors will have to wait in the designated area to be escorted back by the organizers in accordance with their instructions. **Parc Ferme Rules Apply in the Holding Area**. Any competitor found violating this rule will be disqualified.
- 12.9 The procedures and other details of the drag shall be informed to all competitors at the **Drivers Briefing Official / Whatsapp Group / Official Mobile Application**
- 12.10 The CLASS & CATEGORY Winners will be determined by the fastest timings. All class/category-winning vehicles will be then taken to Parc Ferme for post event scrutiny.
- 12.11 The car used for practice cannot be changed on the race day. If done will entail disqualification. Any tampering with or attempt to transfer competition and scrutiny stickers will entail disqualification and the competitors will be reported to the stewards. The chief scrutineer shall be the sole authority to determine whether any such attempts have been made.
- 12.12 Each competitor will be issued a start card for each eligible run which should be surrendered before taking the start. A start shall not be permitted without the surrender of the card.

### **13. PENALTIES**

- 13.1 False Start / Jump Start: A false start occurs when the vehicle moves forward or backwards from the prescribed position before the Start signal. The penalty for this is DISQUALIFICATION. The Start Marshal's decision will be Final and 60 Seconds will be added to the Elapsed Time in the results.
- 13.2 Refusal to obey officials of the meet may result in DISQUALIFICATION.
- 13.3 Driving dangerously in restricted area may result in DISQUALIFICATION.
- 13.4 Crossing of center line may result in DISQUALIFICATION
- 13.5 If a competitor arrives late for staging, he/she shall not be allowed to start
- 13.6 Any driver found riding fast, rashly or negligently, or practicing or tuning their cars on the track, may be DISQUALIFIED.

- 13.7 Any competitor who does not have his / her I.D. Tag may not be allowed to start.
- 13.8 There will be a speed limit on the return run of 60 KMPH. Any competitor found breaking this speed limit MAY BE DISQUALIFIED
- 13.9 The Stewards of the meet may adjudicate on any matter not covered by these regulations and impose penalties in accordance with the Code.
- 13.10 Burnouts are PERMITTED only in the pre stage area.
- 13.11. A participant found not conforming to these Supplementary regulations or by refusing to make their vehicle available for inspection may be disqualified from the event.
- 13.12 Disqualification if a car is found over bored beyond its cubic capacity allowed in its class.
- 13.13 **The car used for qualifying cannot be changed on the race day. Any infringement of the rule will be results in Disqualification.**

#### 14. RESULTS

- 14.1 The driver with the fastest Elapsed time (ET) will be declared the winner. ET is the time taken by the driver to cover the prescribed distance from the start line beam to the finish line beam.
- 14.2 Results will be posted on the official notice board / Official Whatsapp Group after each class finishes.
- 14.3 Results may also be displayed on screens after each race.
- 14.4 **Tie Breaker:** In case of a tie in ET, the competitor with the least Reaction Time (RT) shall be declared the winner. Reaction Time is the time taken by a competitor to cross the start line after the Green GO Light comes on. If the Tie is still not resolved, the award/s will be divided amongst both the competitors.
- 14.5 If a car is disqualified for technical or any other reason, the car placed behind him will move up to take the position.

#### 15. PROTEST & APPEALS

- 15.1 All protests shall be lodged to the Clerk of the Course within 30 minutes of the provisional results being posted. The protest fee, as set by the FMSCI, is Rs. 18,000/- + GST, or at the rates prescribed by the FMSCI from time to time.
- 15.2 The protest must be in writing and submitted to the COC, or in his absence, the Stewards of the meet, along with the protest fee.
- 15.3 If the protest requires the dismantling and the re-assembly of different parts of a car the claimant must pay an additional deposit of Rs.10, 000 /- per component. This amount will be handed over to the driver whose car is opened, if the protest is unfounded/ turned down.
- 15.4 The expenses incurred by the work and for the transport of the car shall be borne by the claimant if the protest is unfounded, or by the competitor against whom the protest is lodged if it is upheld.

- 15.5** If the protest is unfounded, and if the expenses incurred by the protest (Scrutineering, transport, etc.) are higher than the amount of the deposit, the difference shall be borne by the claimant. Conversely, if the expenses are less, the difference shall be returned to them.
- 15.6** Should the owner/driver of a protested vehicle refuse to make the vehicle available for inspection, or refuse to disassemble the appropriate equipment, it will be classed as acknowledgement of the specified illegality.
- 15.7** The appeal fee, as set by the FMSCI, is Rs. 96,000/- + GST to be paid with grounds of appeal within 96 hours.

## **16. PRIZES & TROPHIES**

### **16.1 For the overall championship:**

- 1<sup>st</sup> position per class: Trophy**  
**2<sup>nd</sup> position per class: Trophy**  
**3<sup>rd</sup> Position per class: Trophy**

### **16.2 Team Championship**

- 1<sup>st</sup> Position per class: Trophy**  
**(The organiser reserves the right to OFFER PRIZE or ISSUE START MONEY)**

### **16.3 For Each Race there will be prizes as per below:**

- 1<sup>st</sup> in Class: Trophy for driver + Winning Tuner**  
**2<sup>nd</sup> in Class: Trophy**  
**3<sup>rd</sup> in Class: Trophy**

### **16.4 Best Tuner of the day:**

Trophy. This award goes to the tuner whose car clocks the quickest time of the day.

### **16.5 Fastest time of the day - Trophy**

**ARTICLE 17 JUDGES OF FACT - All Marshals & Officials shall be judges of fact.**

## **18. IDENTIFICATION OF OFFICIALS**

### **19. NAME AND PHOTOGRAPHS OF CRO**

Safety Marshal	Orange
Safety Officer	Orange with white stripe and text
Post Chief	Blue with white stripe and text
Media	Green
Stage Commander	Red with text
Competitor Relations Officer	Red Jacket or Red Tabard
Medical	White
Radio	Yellow with blue mark
Scrutineer	Black

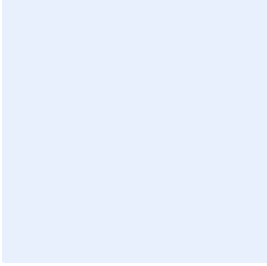
	
<b>TARIQ MOHSIN</b>	<b>CRO NAME</b>
<b>+917022450500</b>	<b>MOBILE</b>
<b>tariq.m@vroomgeneva.com</b>	<b>email</b>

Will be present at:

- At the Secretariat.
- At the start of the scrutineering.
- Near the "PIT AREA".

**20. Organizers holding a valid 2024 FMSCI Permit for an event are covered for:**

**20.1 Competitors :** A maximum of 250 competitors with valid FMSCI Competition License participating in various events across the Country on a given day are covered for Personal Accident Insurance for Rs. 5 lakhs with Rs. 1 Lakh medical expense extension per person.

**20.2 Officials:** A maximum of 100 officials officiating in various events across the Country on a given day are covered for Personal Accident Insurance for Rs.25 lakhs with Rs.5 lakhs medical expense extension per person.

20.3 THESE INSURANCES ARE ISSUED BY UNITED INDIA INSURANCE COMPANY LTD AND VALID DURING THE RUNNING OF THE EVENT ONLY. ORGANIZERS / COMPETITORS ARE ADVISED TO TAKE ANY ADDITIONAL INSURANCES THEY MAY DEEM FIT. CONTACT: S.MANIKANDAN@STENHOUSE.IN



## **21 .SUSTAINABILITY**

We, the organisers of the FMSCI INDIAN NATIONAL DRAG RACING CHAPIOSHIP - (4W) follow the FMSCI Sustainability Guidelines, the FIA Guide to Sustainable Events and the FIA Environmental Code, to the best of our abilities, for the future of our sport, and to respect nature and the environment. We ask you to

1. Use an environment mat or other approved system while servicing or refueling in order to prevent spillage of oil and fuel into the ground.
2. Use the oil collection containers available in the pits when disposing of used oil.
3. Bring refillable water bottles.
4. Use waste bins for all rubbish.
5. Please leave your pits/ service area clean, so that there is no trace of your activity.
6. Not leave used tyres or parts behind. Dispose of them correctly.
7. Download the FIA Smart Driving Challenge App to evaluate your CO2 emissions.

Please help us make our sport clean and environmentally friendly.

**( Note: For further queries regarding the guidelines, please contact the Chairperson, Environment and Sustainability Commission, Anita Nanjapa on +91 9442158283 )**

**“MOTOR SPORTS CAN BE DANGEROUS”**  
**“Despite the organizers taking all responsible precautions unavoidable accidents can happen. You are present here at your own risk**

## APPENDIX 1: COMPETITION NUMBERS & ADVERTISING

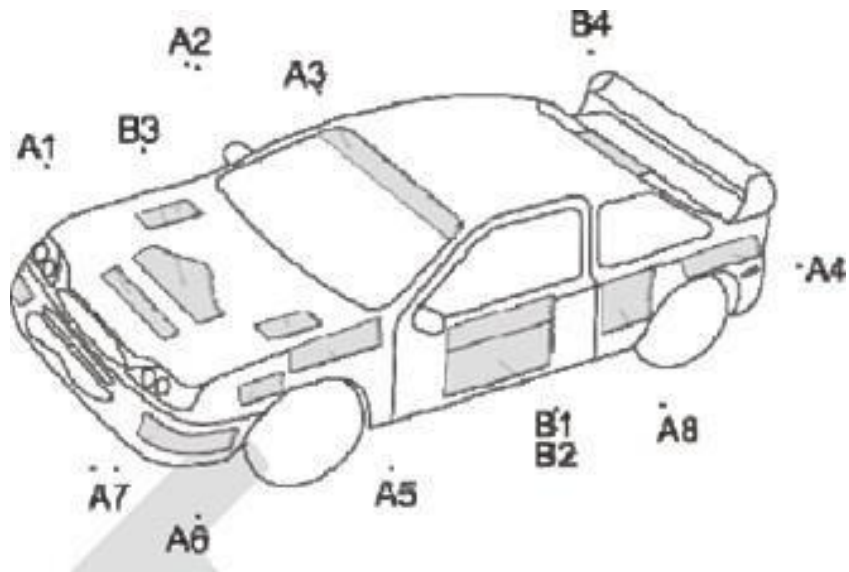

- A1 : TBA
- A2 : TBA
- A3 : TBA Club/Sponsor
- A4 : TBA Sponsor
- A5 : TBA Sponsor
- A6 : TBA
- A7 : TBA
- A8 : TBA
- B1 ~ B3: Competition Number